

Wingliner Classic

THE UNIVERSAL

The Wingliner Classic: besides being the bestseller, it is also the favorite of all drivers. Opening in seconds, the system saves a lot of time and eliminates the annoying handling of tarpaulins and sliding curtains. Demanded worldwide in a variety of climatic regions and industry sectors, the Wingliner Classic has been doing its job reliably since 1996, performing its function in the transportation of beverages, woods, chemicals, vehicles and so on.

ADVANTAGES

Fast and simple opening

Theft protection

Permanent advertising space

Rain shelter

Variable load fastening

Effective sealing

Simple assembly

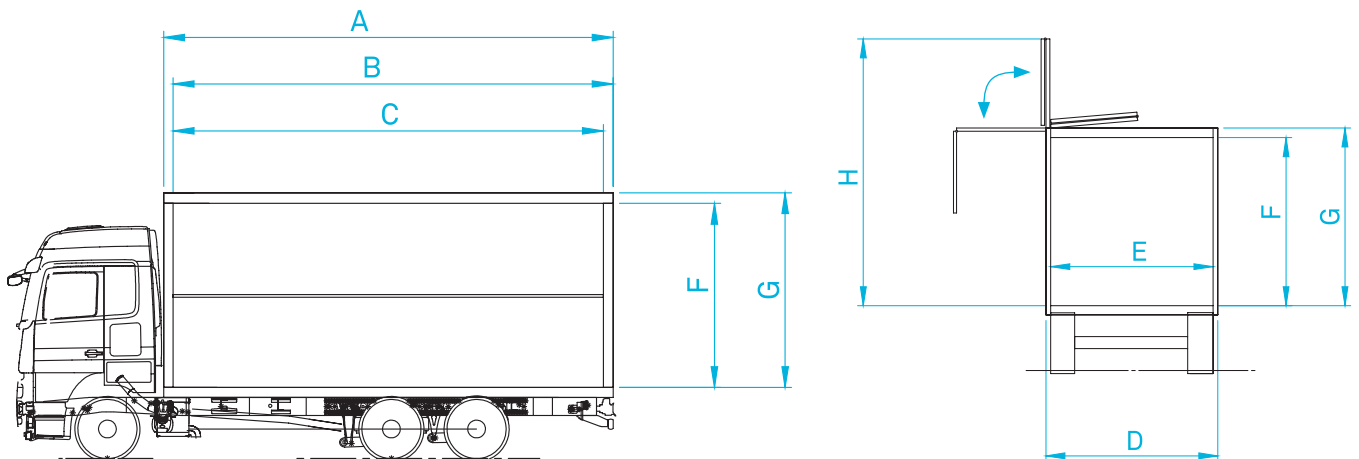

A Overall external length

E Loading width = 2.435 mm

B Internal usable loading length = $A - 145$ mm

F Loading height

C Usable loading length from the side = $B - 145$ mm

G Overall height when closed = $F + 180$ mm

D Overall external width = 2.550 mm

H Overall height when opened 180° = $G + (F / 2) + 140$ mm

CERTIFICATION	WINGLINER CLASSIC	REQUESTED CONFIGURATION
Beverages	X	
Beer Kegs	X	
Load Safety - XL	X	
Explosion Protection - EX	Optional	
Chemicals	Optional	
Automotive Industry	Optional	

LOADING SIZING

Loading height sizing in steps of 50 mm for assemblies with Aluminum Snap or Tarpaulin; Composite panel and temperglass with regular sizing	1.500 - 3.000 mm
Loading length with regular sizing	< 10.000 mm
"Internal width between sidewalls (without palett stop)"	2.481 mm
Feasibility for structure with special length and width	

SIDEWALL VERSIONS

One-sided opening configuration (left or right)	X
Bilateral opening configuration	X
Aluminum snap 25 mm	X
Composite panel with 1,2 mm of aluminum layer	X
Composite panel with 0,6 mm of aluminum layer	X
Aluminum core	X
"Tarpaulin and aluminum snap 25 mm (Tarpaulin not included)"	X
PEP-core translucent	-
Tempered glass 25 mm	-
Lifting roof	X

VEHICLE WEIGHT

(t)	7,5 - 26,0
-----	------------

NOTES / COMMENTARIES